

AMC_M7_2.1.4.2_ArchiMate Viewpoints

ArchiMate View Point

Author:Modeliosoft

Version:1.0

Publication:13/04/2017 Copyright

Modeliosoft, All Rights Reserved

Modeliosoft

Table of Contents

1	AMC_M7_2.1.4_ArchiMate Viewpoints.....	3
1.1	C.1.10_Service Realization View	3
1.2	C.1.11_Physical View.....	4
1.3	C.1.12_Layered View.....	5
1.4	C.1.1_Organization view	7
1.5	C.1.2_Business Process Cooperation view	9
1.6	C.1.3_Product View	10
1.7	C.1.4_Application Cooperation View	11
1.8	C.1.5_Application Usage View.....	12
1.9	C.1.6_Implementation and Migration View.....	13
1.10	C.1.7_Technology View	14
1.11	C.1.8_Technology Usage View	15
1.12	C.1.9_Information Structure View	16
1.13	C.2.1_Stakeholder View	17
1.14	C.2.2_Goal Realization View	19
1.15	C.2.3_Requirements Realization View	20
1.16	C.2.4_Motivation View.....	21
1.17	C.3.1_Strategy View	22
1.18	C.3.2_CapabilityMapView	23
1.19	C.3.3_Outcome Realization View	24
1.20	C.3.4_Resource Map View	25
1.21	C.4.1_Project View	25
1.22	C.4.2_Migration View.....	26
1.23	C.4.3_Implementation and Migration View.....	27

1 AMC_M7_2.1.4_ArchiMate Viewpoints

The current chapter presents the "AMC_M7_2.1.4_ArchiMate Viewpoints" view point described using the ArchiMate standard. It lists the views and nomenclatures composing the view point.

The table below lists the views and nomenclatures presented in this chapter.

Name	Type	Description
C.1.10 Service Realization View	View	
C.1.11 Physical View	View	
C.1.12 Layered View	View	
C.1.1 Organization view	View	
C.1.2 Business Process Cooperation view	View	
C.1.3 Product View	View	
C.1.4 Application Cooperation View	View	
C.1.5 Application Usage View	View	
C.1.6 Implementation and Migration View	View	
C.1.7 Technology View	View	
C.1.8 Technology Usage View	View	
C.1.9 Information Structure View	View	
C.2.1 Stakeholder View	View	
C.2.2 Goal Realization View	View	
C.2.3 Requirements Realization View	View	
C.2.4 Motivation View	View	
C.3.1 Strategy View	View	
C.3.2 CapabilityMapView	View	
C.3.3 Outcome Realization View	View	
C.3.4 Resource Map View	View	
C.4.1 Project View	View	
C.4.2 Migration View	View	
C.4.3 Implementation and Migration View	View	

Table 1 Views and Nomenclatures of the AMC_M7_2.1.4_ArchiMate Viewpoints view point.

The table below lists the sub view points of the current view point.

1.1 C.1.10_Service Realization View

This chapter describes the "C.1.10_Service Realization View" view defined in the "AMC_M7_2.1.4_ArchiMate Viewpoints" view point.

C.1.10_Service Realization Viewpoint

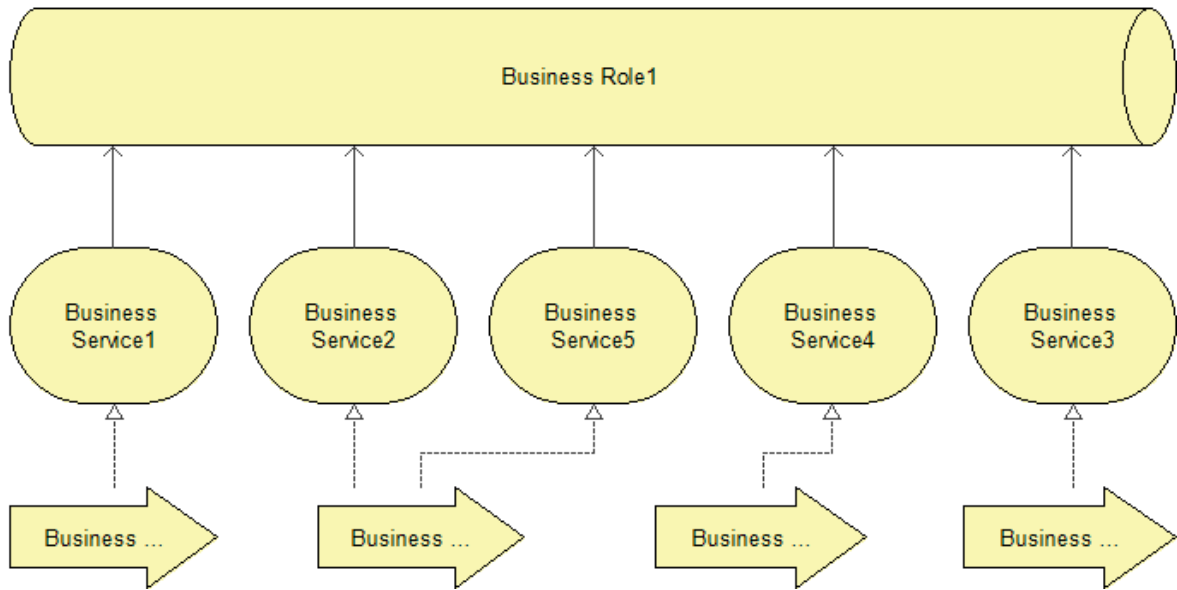

Figure 1 C.1.10_Service Realization View

The table below lists the current view's elements.

Name	Description	Refined by
Business Process1		
Business Process2		
Business Process3		
Business Process4		
Business Role1		
Business Service1		
Business Service2		
Business Service3		
Business Service4		
Business Service5		

Table 2 List of the elements defined in the C.1.10_Service Realization View view.

1.2 C.1.11_Physical View

This chapter describes the "C.1.11_Physical View" view defined in the "AMC_M7_2.1.4_ArchiMate Viewpoints" view point.

C.1.11_Physical Viewpoint

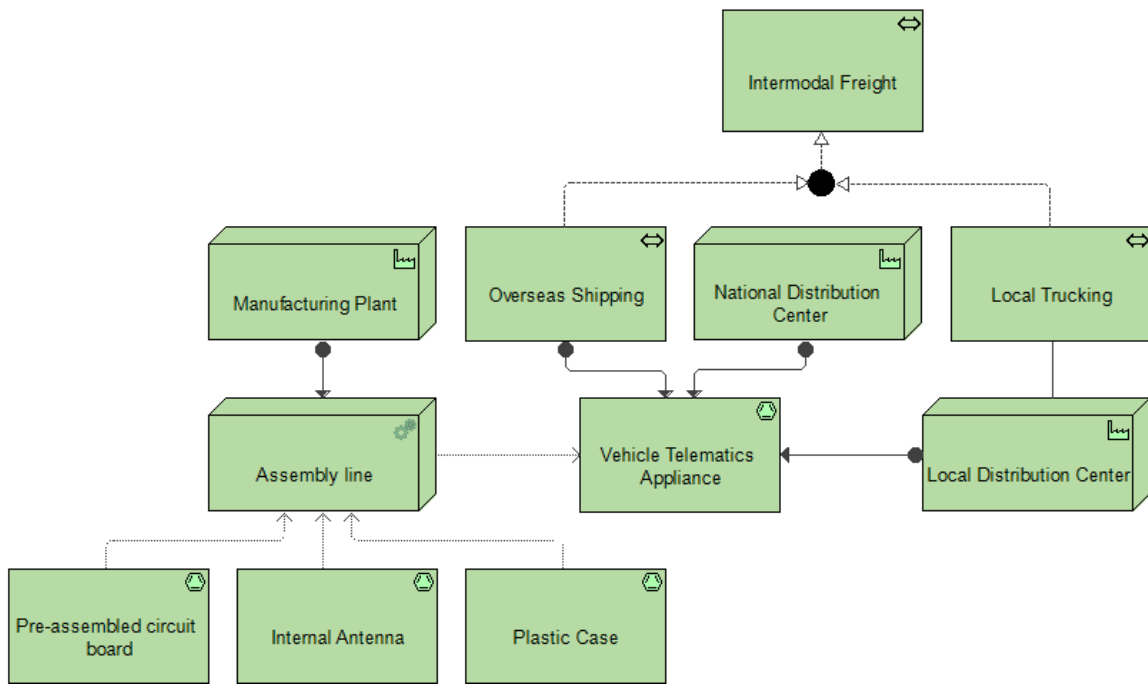

Figure 2 C.1.11_Physical View

The table below lists the current view's elements.

Name	Description	Refined by
Assembly line		
Intermodal Freight		
Internal Antenna		
Local Distribution Center		
Local Trucking		
Manufacturing Plant		
National Distribution Center		
Overseas Shipping		
Plastic Case		
Pre-assembled circuit board		
Vehicle Telematics Appliance		

Table 3 List of the elements defined in the C.1.11_Physical View view.

1.3 C.1.12_Layered View

This chapter describes the "C.1.12_Layered View" view defined in the "AMC_M7_2.1.4_ArchiMate Viewpoints" view point.

C.1.12_Layered Viewpoint

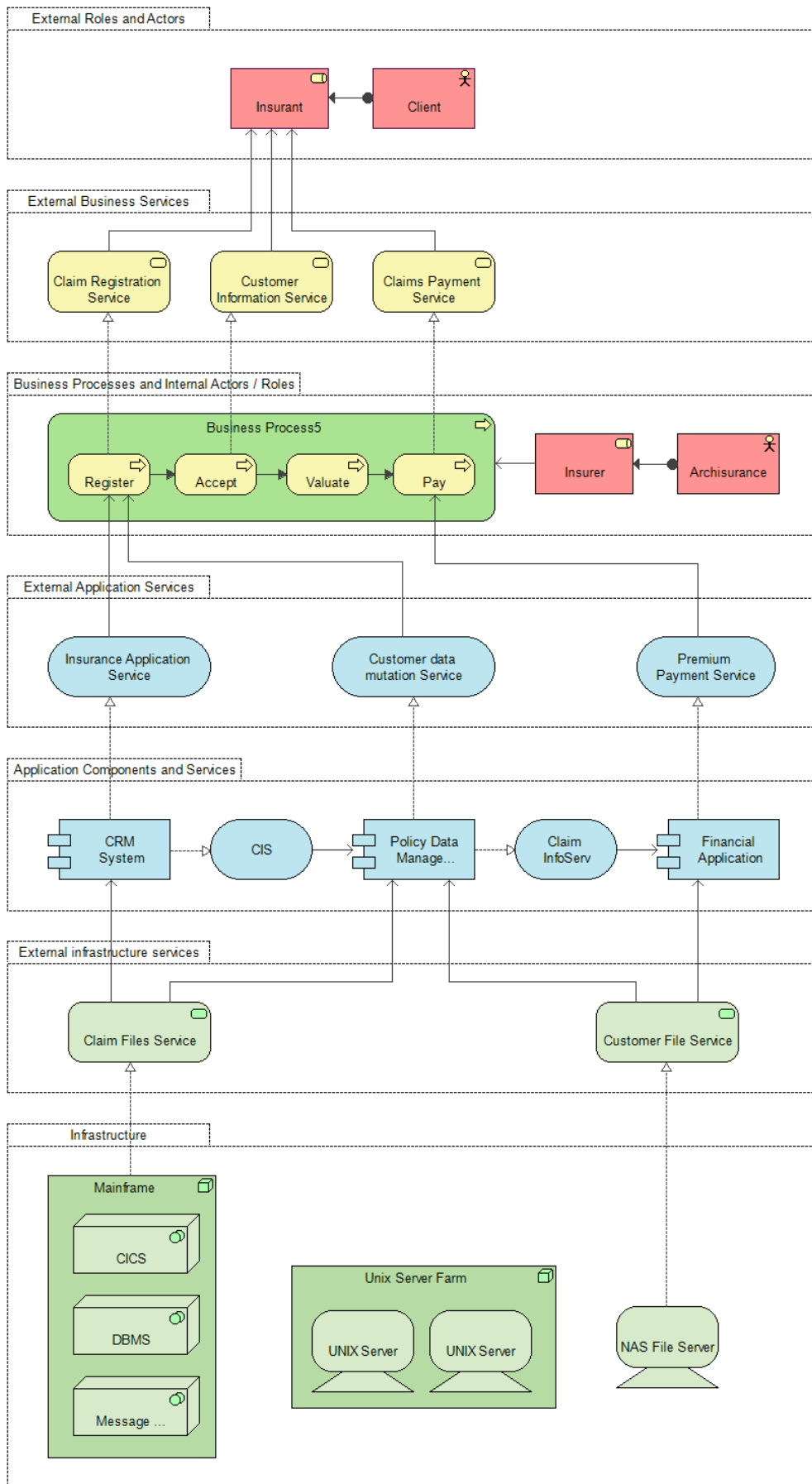

Figure 3 C.1.12_Layered View

The table below lists the current view's elements.

Name	Description	Refined by
Accept		
Application Components and Services		
Archinsurance		
Business Process5		
Business Processes and Internal Actors / Roles		
CICS		
CIS		
CRM System		
Claim Files Service		
Claim InfoServ		
Claim Registration Service		
Claims Payment Service		
Client		
Customer File Service		
Customer Information Service		
Customer data mutation Service		
DBMS		
External Application Services		
External Business Services		
External Roles and Actors		
External infrastructure services		
Financial Application		
Infrastructure		
Insurance Application Service		
Insurant		
Insurer		
Mainframe		
Message Queueing		
NAS File Server		
Pay		
Policy Data Management		
Premium Payment Service		
Register		
UNIX Server		
UNIX Server		
Unix Server Farm		
Valuate		

Table 4 List of the elements defined in the C.1.12_Layered View view.

1.4 C.1.1_Organization view

This chapter describes the "C.1.1_Organization view" view defined in the "AMC_M7_2.1.4_ArchiMate Viewpoints" view point.

C.1.1_Organization view

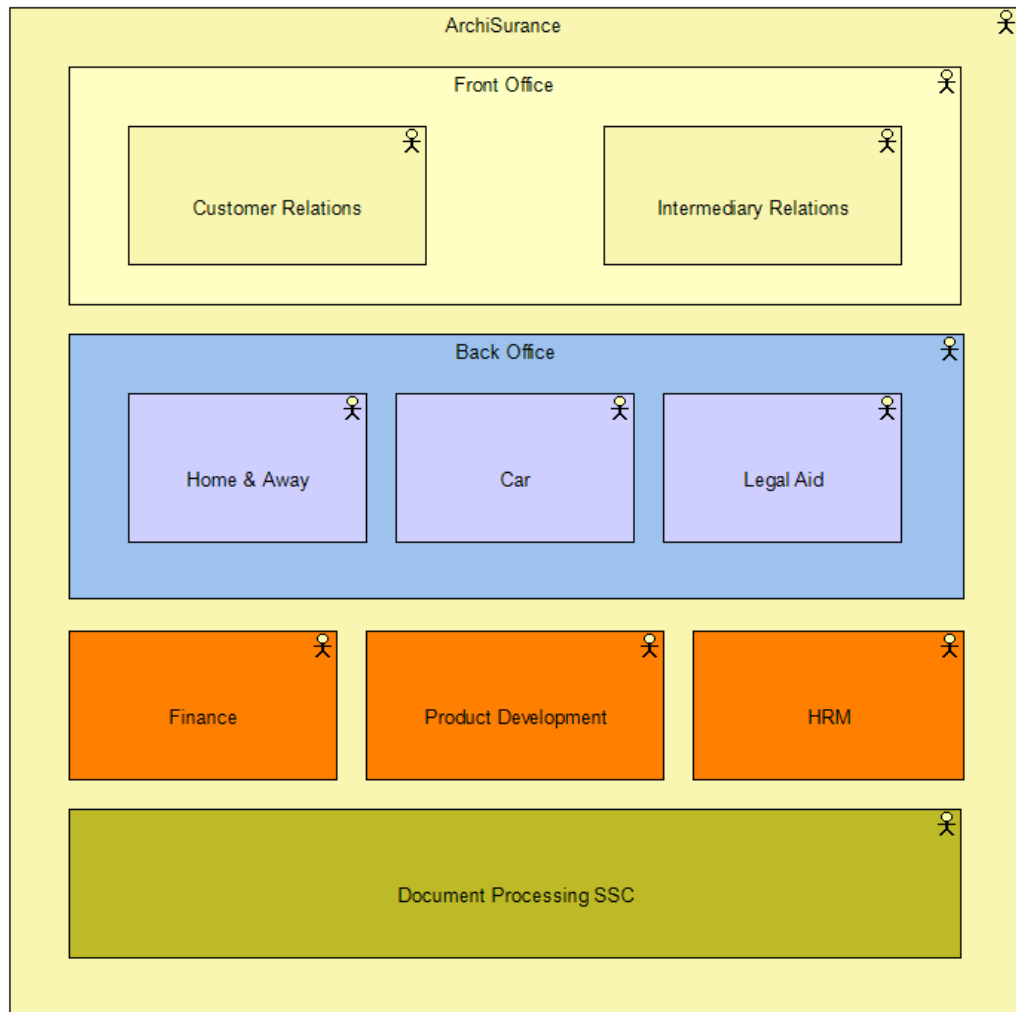

Figure 4 C.1.1_Organization view

The table below lists the current view's elements.

Name	Description	Refined by
ArchiSurance		
Back Office		
Car		
Customer Relations		
Document Processing SSC		
Finance		
Front Office		
HRM		
Home & Away		
Intermediary Relations		
Legal Aid		
Product Development		

Table 5 List of the elements defined in the C.1.1_Organization view view.

1.5 C.1.2_Business Process Cooperation view

This chapter describes the "C.1.2_Business Process Cooperation view" view defined in the "AMC_M7_2.1.4_ArchiMate Viewpoints" view point.

C.1.2_Business Process Cooperation view

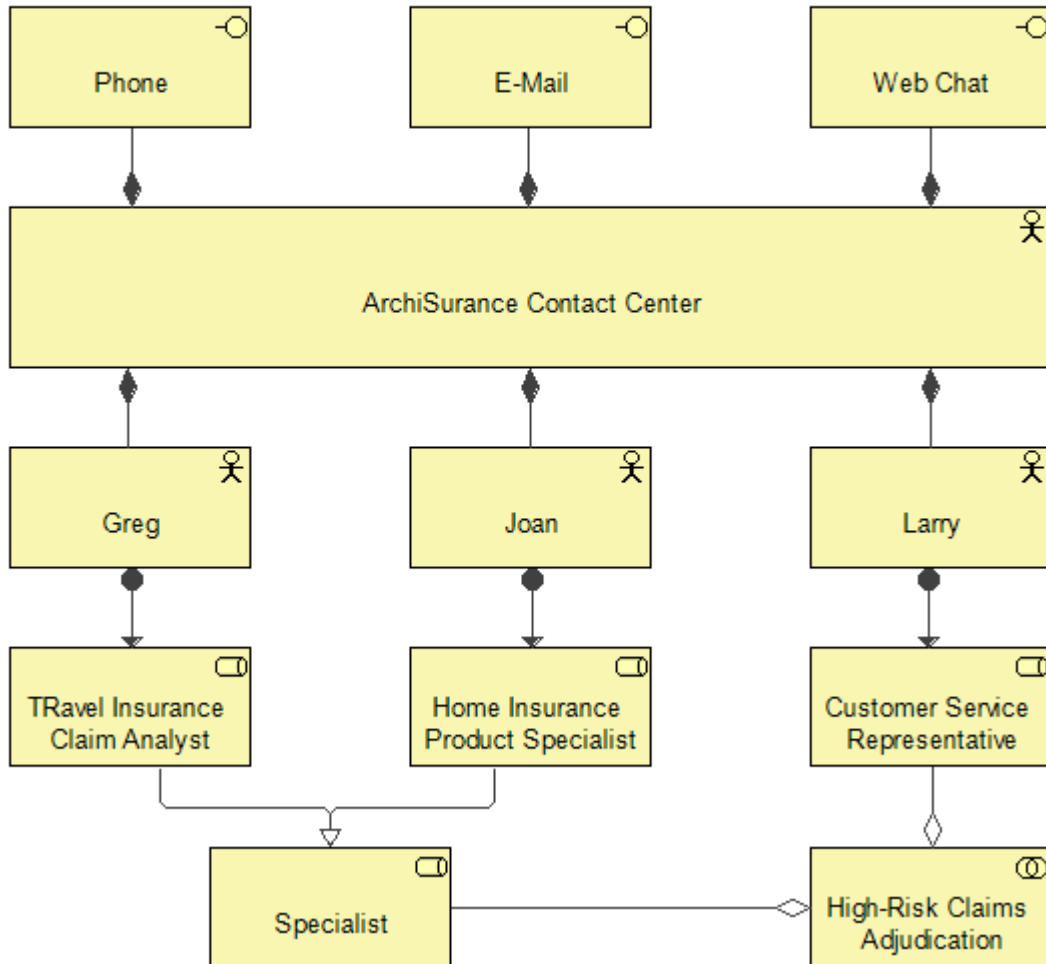

Figure 5 C.1.2_Business Process Cooperation view

The table below lists the current view's elements.

Name	Description	Refined by
ArchiSurance Contact Center		
Customer Service Representative		
E-Mail		
Greg		
High-Risk Claims Adjudication		
Home Insurance Product Specialist		
Joan		
Larry		

Name	Description	Refined by
Phone		
Specialist		
TRavel Insurance Claim Analyst		
Web Chat		

Table 6 List of the elements defined in the C.1.2_Business Process Cooperation view view.

1.6 C.1.3_Product View

This chapter describes the "C.1.3_Product View" view defined in the "AMC_M7_2.1.4_ArchiMate Viewpoints" view point.

C.1.3_Product Viewpoint

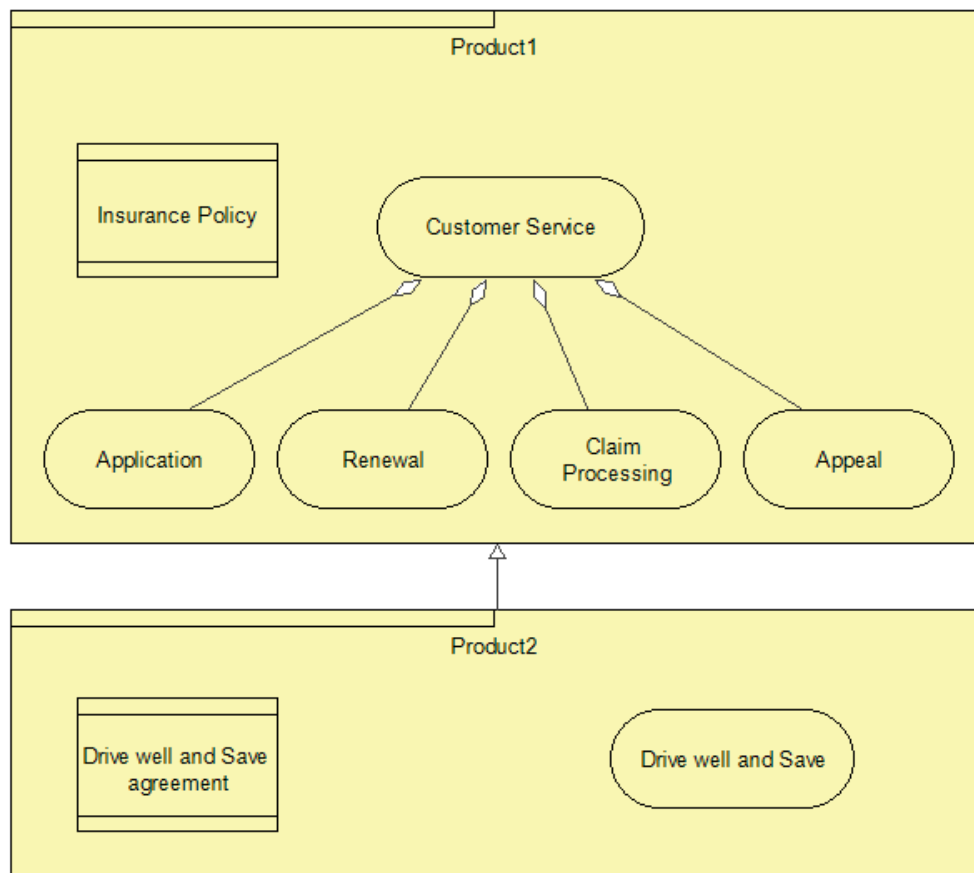

Figure 6 C.1.3_Product View

The table below lists the current view's elements.

Name	Description	Refined by
Appeal		
Application		
Claim Processing		
Customer Service		

Name	Description	Refined by
Drive well and Save		
Drive well and Save agreement		
Insurance Policy		
Product1		
Product2		
Renewal		

Table 7 List of the elements defined in the C.1.3_Product View view.

1.7 C.1.4_Application Cooperation View

This chapter describes the "C.1.4_Application Cooperation View" view defined in the "AMC_M7_2.1.4_ArchiMate Viewpoints" view point.

C.1.4_Application Cooperation Viewpoint

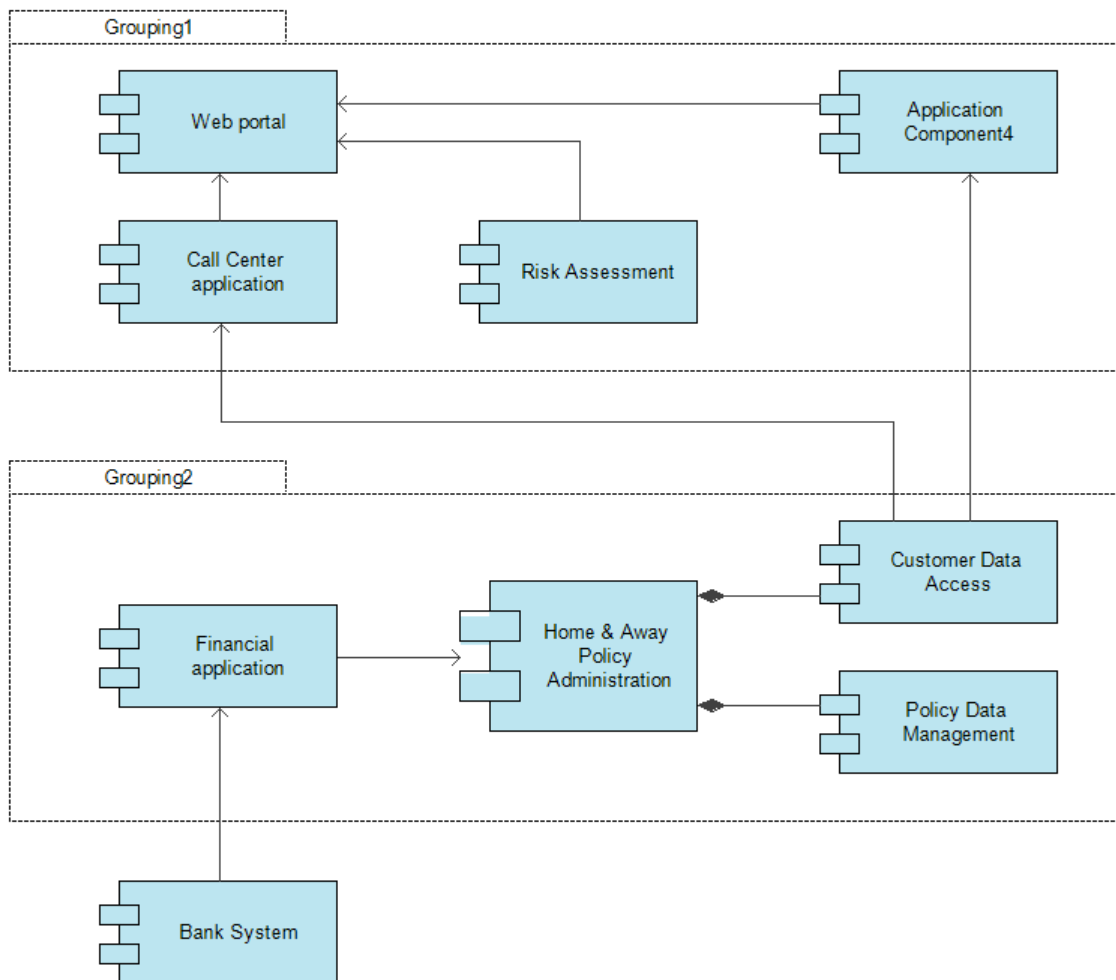

Figure 7 C.1.4_Application Cooperation View

The table below lists the current view's elements.

Name	Description	Refined by
Application Component4		
Bank System		
Call Center application		
Customer Data Access		
Financial application		
Grouping1		
Grouping2		
Home & Away Policy Administration		
Policy Data Management		
Risk Assessment		
Web portal		

Table 8 List of the elements defined in the C.1.4_Application Cooperation View view.

1.8 C.1.5_Application Usage View

This chapter describes the "C.1.5_Application Usage View" view defined in the "AMC_M7_2.1.4_ArchiMate Viewpoints" view point.

C.1.5_Application Usage Viewpoint

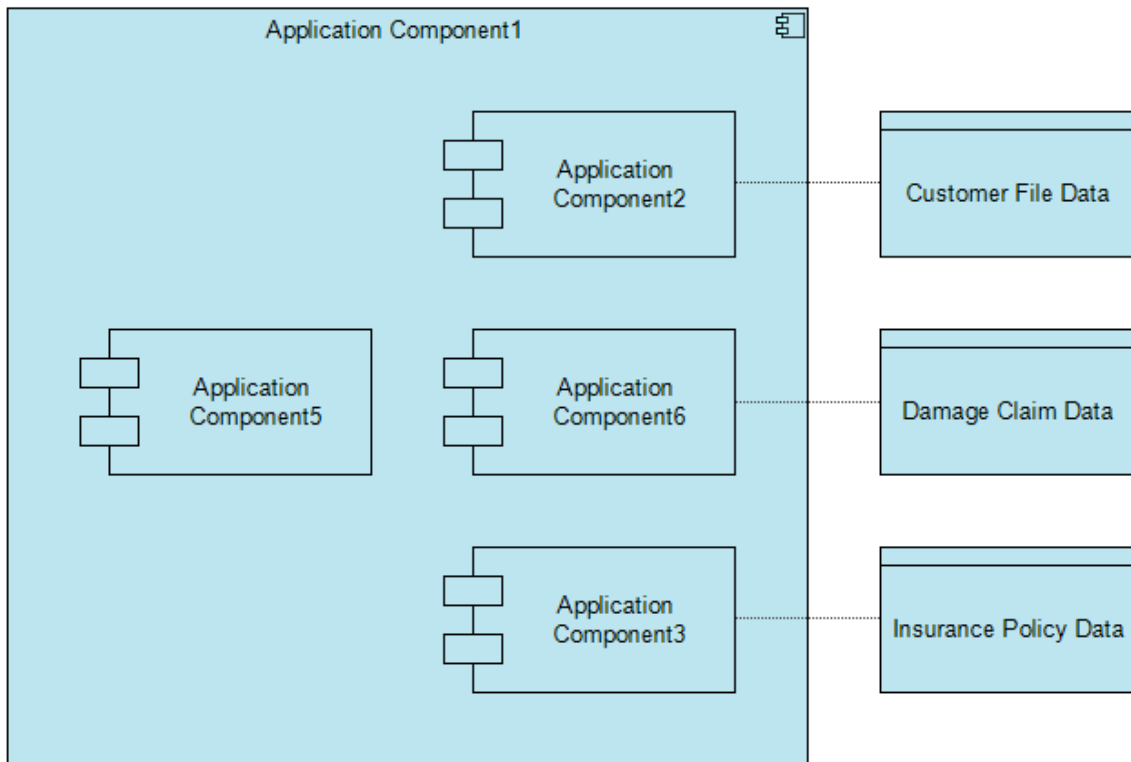

Figure 8 C.1.5_Application Usage View

The table below lists the current view's elements.

Name	Description	Refined by
Application Component1		
Application Component2		
Application Component3		
Application Component5		
Application Component6		
Customer File Data		
Damage Claim Data		
Insurance Policy Data		

Table 9 List of the elements defined in the C.1.5_Application Usage View view.

1.9 C.1.6_Implementation and Migration View

This chapter describes the "C.1.6_Implementation and Migration View" view defined in the "AMC_M7_2.1.4_ArchiMate Viewpoints" view point.

C.1.6_Implementation and Deployment Viewpoint

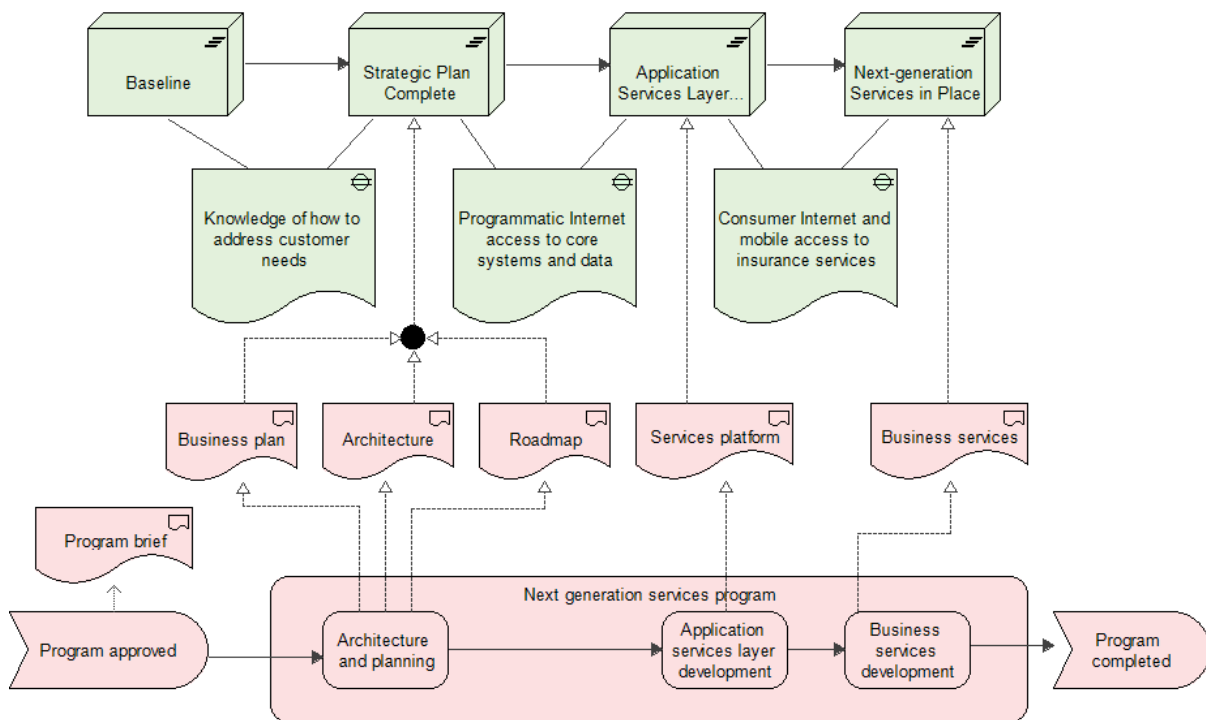

Figure 9 C.1.6_Implementation and Migration View

The table below lists the current view's elements.

Name	Description	Refined by
Application Services Layer in Place		
Application services layer development		
Architecture		

Name	Description	Refined by
Architecture and planning		
Baseline		
Business plan		
Business services		
Business services development		
Consumer Internet and mobile access to insurance services		
Knowledge of how to address customer needs		
Next generation services program		
Next-generation Services in Place		
Program approved		
Program brief		
Program completed		
Programmatic Internet access to core systems and data		
Roadmap		
Services platform		
Strategic Plan Complete		

Table 10 List of the elements defined in the C.1.6_Implementation and Migration View view.

1.10 C.1.7_Technology View

This chapter describes the "C.1.7_Technology View" view defined in the "AMC_M7_2.1.4_ArchiMate Viewpoints" view point.

C.1.7_Technology Viewpoint

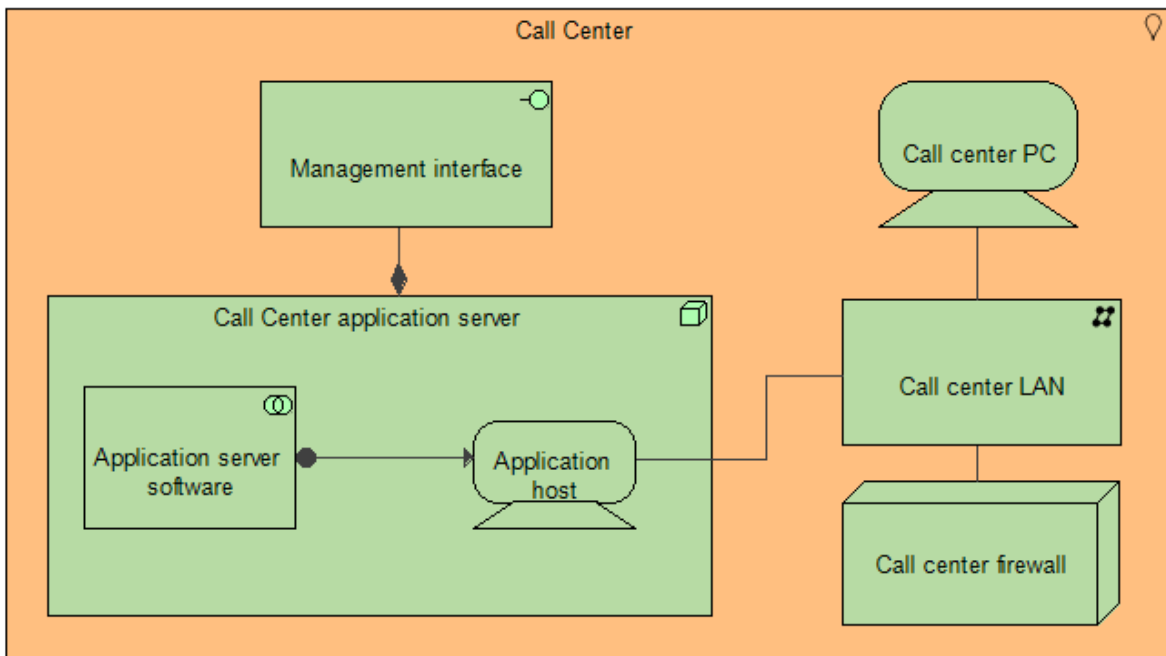

Figure 10 C.1.7_Technology View

The table below lists the current view's elements.

Name	Description	Refined by
Application host		
Application server software		
Call Center		
Call Center application server		
Call center LAN		
Call center PC		
Call center firewall		
Management interface		

Table 11 List of the elements defined in the C.1.7_Technology View view.

1.11 C.1.8_Technology Usage View

This chapter describes the "C.1.8_Technology Usage View" view defined in the "AMC_M7_2.1.4_ArchiMate Viewpoints" view point.

C.1.8_Technology Usage Viewpoint

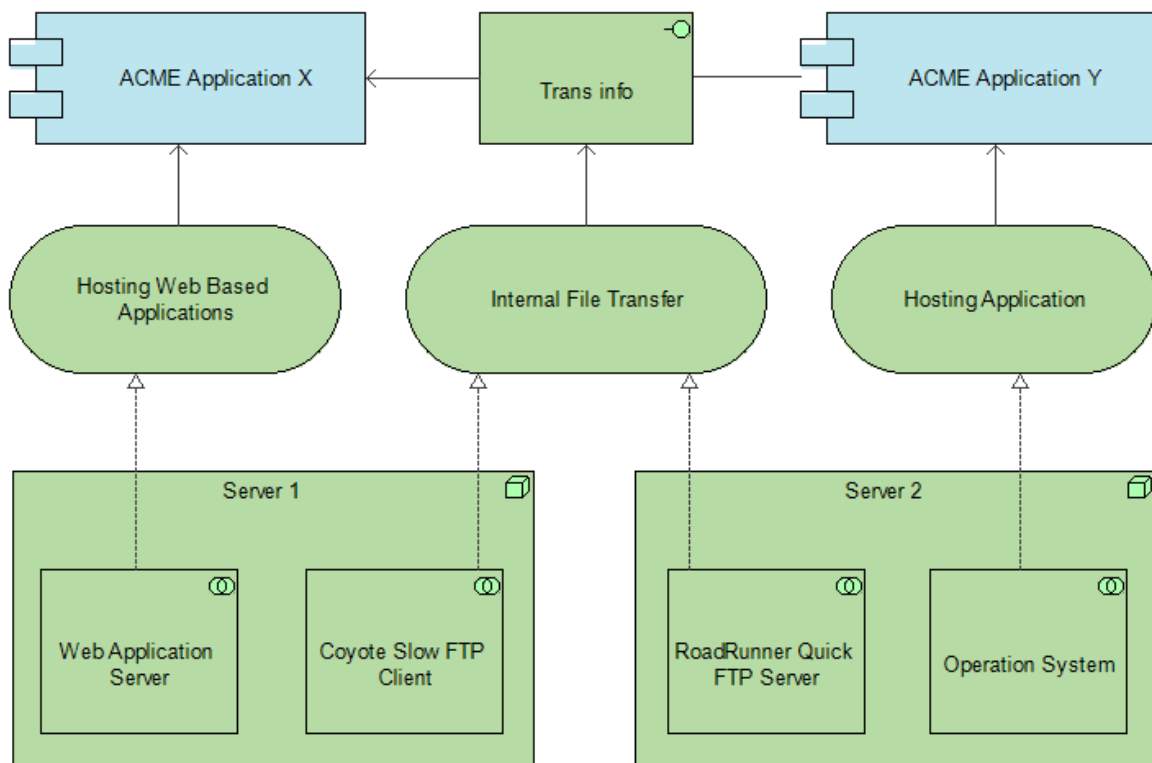

Figure 11 C.1.8_Technology Usage View

The table below lists the current view's elements.

Name	Description	Refined by
------	-------------	------------

Name	Description	Refined by
ACME Application X		
ACME Application Y		
Coyote Slow FTP Client		
Hosting Application		
Hosting Web Based Applications		
Internal File Transfer		
Operation System		
RoadRunner Quick FTP Server		
Server 1		
Server 2		
Trans info		
Web Application Server		

Table 12 List of the elements defined in the C.1.8_Technology Usage View view.

1.12 C.1.9_Information Structure View

This chapter describes the "C.1.9_Information Structure View" view defined in the "AMC_M7_2.1.4_ArchiMate Viewpoints" view point.

C.1.9_Information Structure Viewpoint

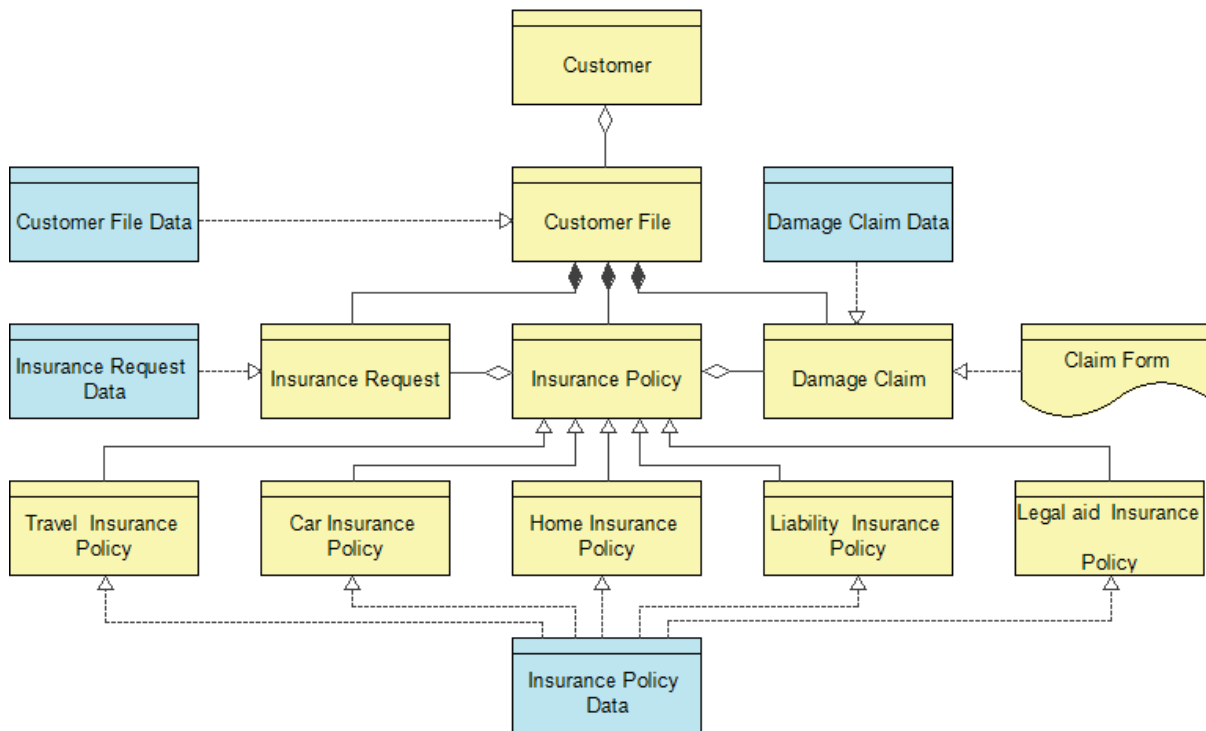

Figure 12 C.1.9_Information Structure View

The table below lists the current view's elements.

Name	Description	Refined by
Car Insurance Policy		
Claim Form		
Customer		
Customer File		
Customer File Data		
Damage Claim		
Damage Claim Data		
Home Insurance Policy		
Insurance Policy		
Insurance Policy Data		
Insurance Request		
Insurance Request Data		
Legal aid Insurance Policy		
Liability Insurance Policy		
Travel Insurance Policy		

Table 13 List of the elements defined in the C.1.9_Information Structure View view.

1.13 C.2.1_Stakeholder View

This chapter describes the "C.2.1_Stakeholder View" view defined in the "AMC_M7_2.1.4_ArchiMate Viewpoints" view point.

C.2.1_ Stakeholder Viewpoint

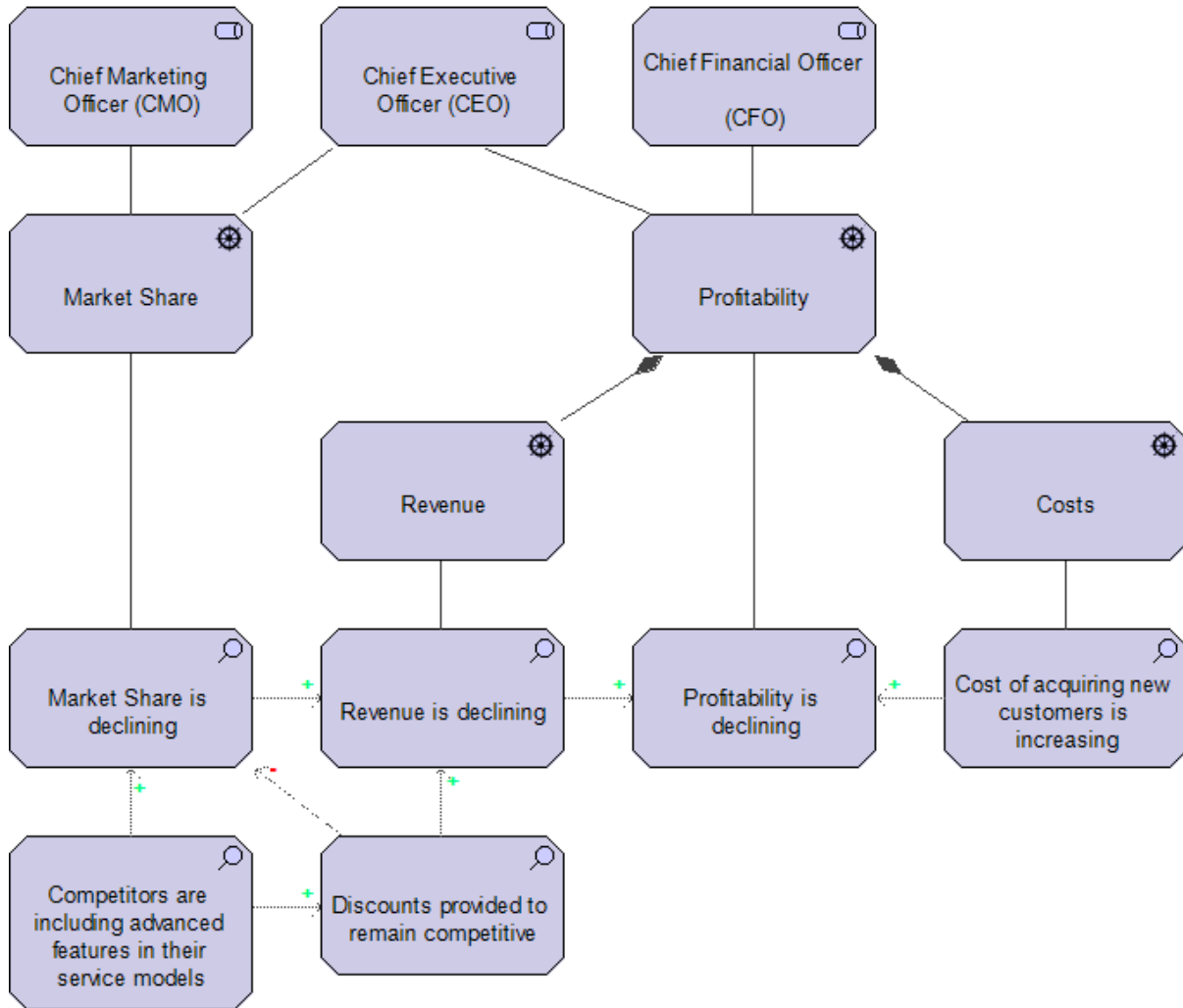

Figure 13 C.2.1_ Stakeholder View

The table below lists the current view's elements.

Name	Description	Refined by
Chief Executive Officer (CEO)		
Chief Financial Officer (CFO)		
Chief Marketing Officer (CMO)		
Competitors are including advanced features in their service models		
Cost of acquiring new customers is increasing		
Costs		
Discounts provided to remain competitive		
Market Share		
Market Share is declining		
Profitability		
Profitability is declining		
Revenue		

Name	Description	Refined by
Revenue is declining		

Table 14 List of the elements defined in the C.2.1_Stakeholder View view.

1.14 C.2.2_Goal Realization View

This chapter describes the "C.2.2_Goal Realization View" view defined in the "AMC_M7_2.1.4_ArchiMate Viewpoints" view point.

C.2.2_Goal Realization Viewpoint

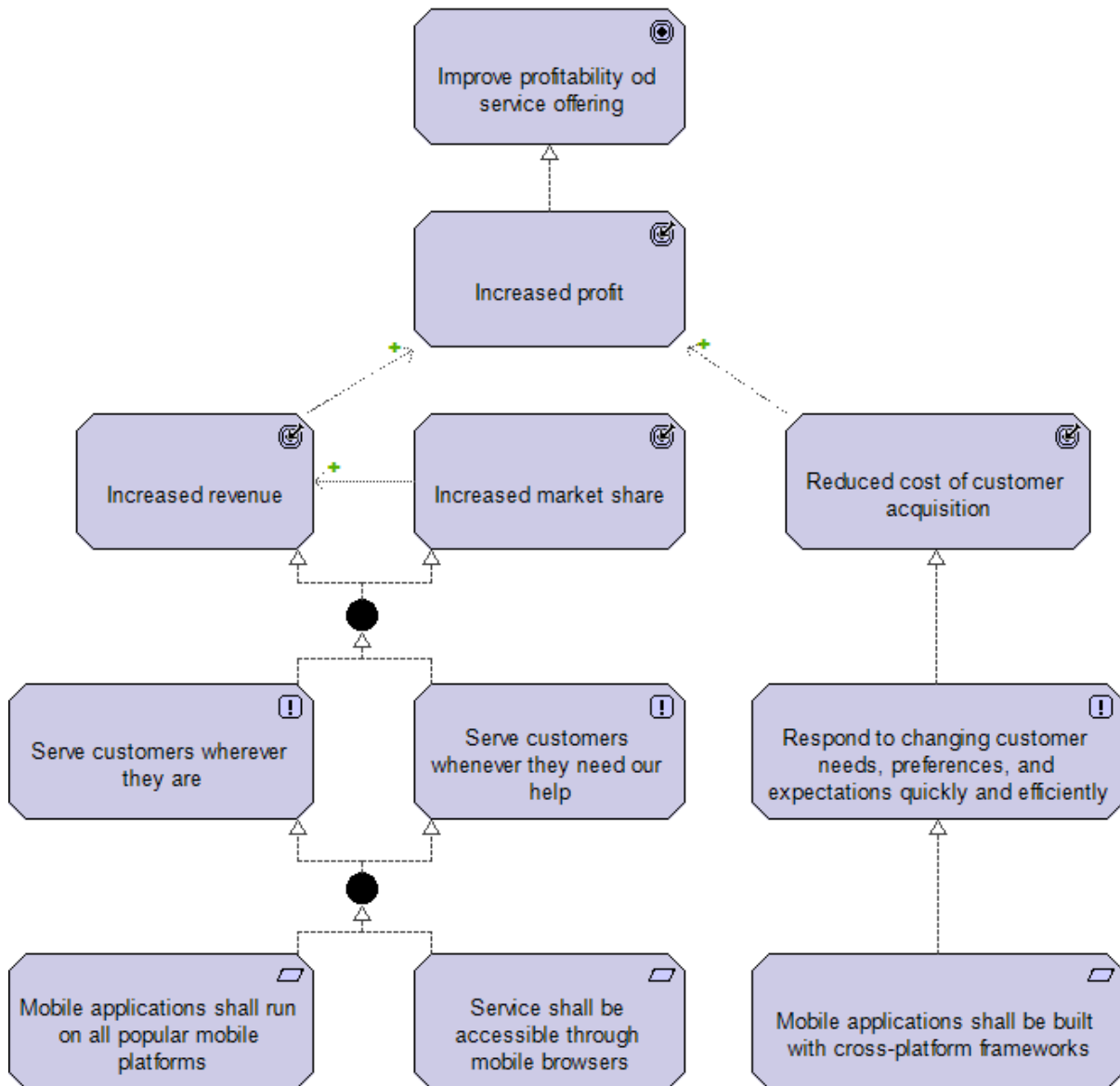

Figure 14 C.2.2_Goal Realization View

The table below lists the current view's elements.

Name	Description	Refined by
Improve profitability of service offering		
Increased market share		
Increased profit		
Increased revenue		
Mobile applications shall be built with cross-platform frameworks		
Mobile applications shall run on all popular mobile platforms		
Reduced cost of customer acquisition		
Respond to changing customer needs, preferences, and expectations quickly and efficiently		
Serve customers whenever they need our help		
Serve customers wherever they are		
Service shall be accessible through mobile browsers		

Table 15 List of the elements defined in the C.2.2_Goal Realization View view.

1.15 C.2.3_Requirements Realization View

This chapter describes the "C.2.3_Requirements Realization View" view defined in the "AMC_M7_2.1.4_ArchiMate Viewpoints" view point.

C.2.3_Requirements Realization Viewpoint

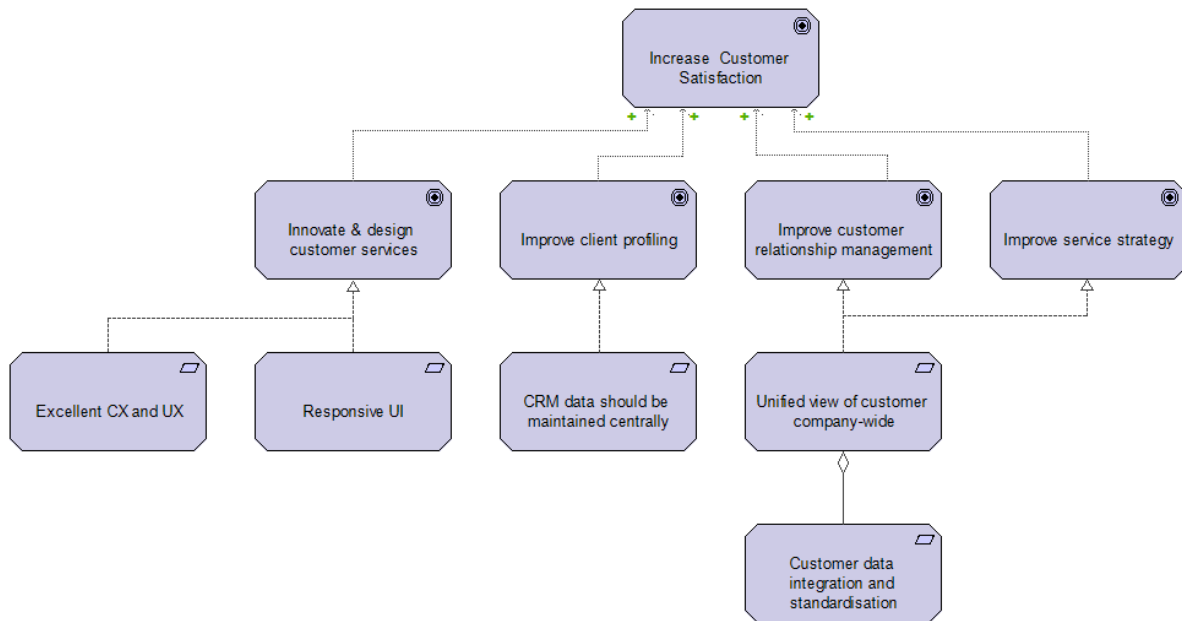

Figure 15 C.2.3_Requirements Realization View

The table below lists the current view's elements.

Name	Description	Refined by
CRM data should be maintained centrally		
Customer data integration and standardisation		
Excellent CX and UX		

Name	Description	Refined by
Improve client profiling		
Improve customer relationship management		
Improve service strategy		
Increase Customer Satisfaction		
Innovate & design customer services		
Responsive UI		
Unified view of customer company-wide		

Table 16 List of the elements defined in the C.2.3_Requirements Realization View view.

1.16 C.2.4_Motivation View

This chapter describes the "C.2.4_Motivation View" view defined in the "AMC_M7_2.1.4_ArchiMate Viewpoints" view point.

C.2.4_Motivation Viewpoint

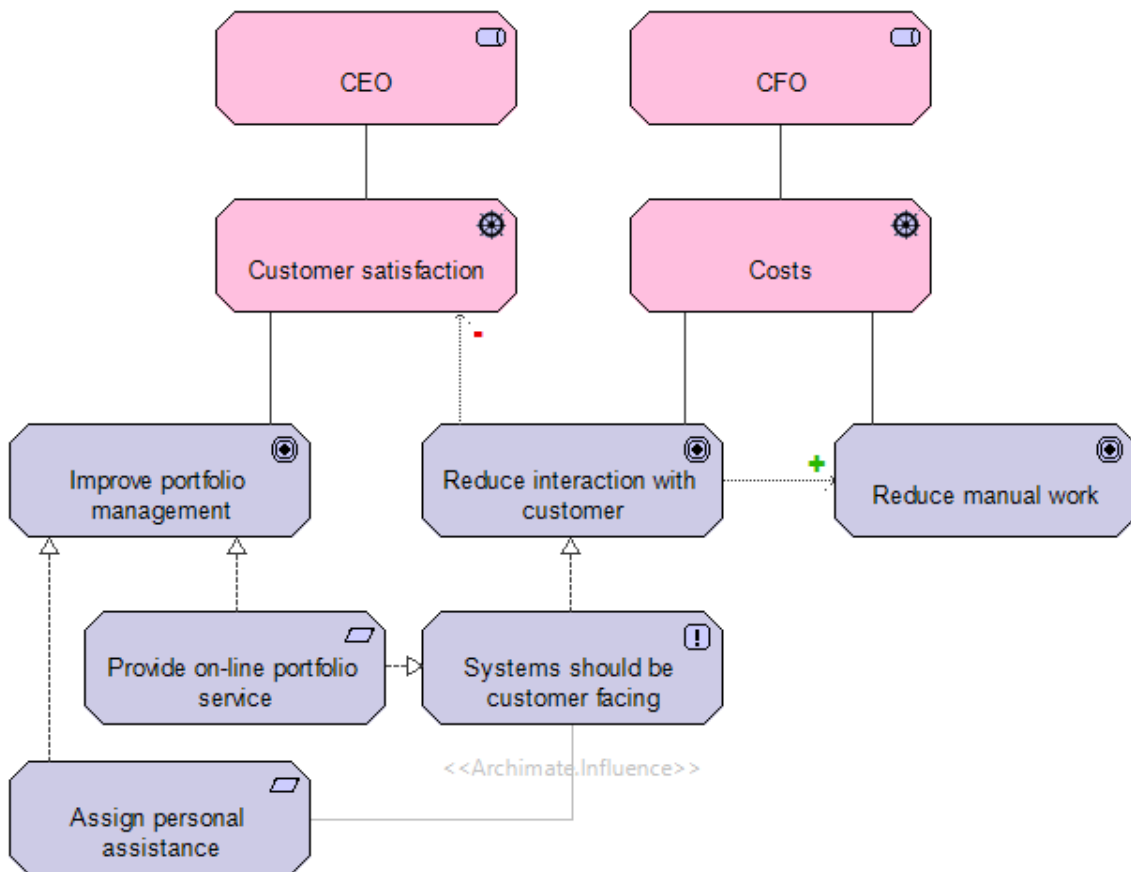

Figure 16 C.2.4_Motivation View

The table below lists the current view's elements.

Name	Description	Refined by

Name	Description	Refined by
Assign personal assistance		
CEO		
CFO		
Costs		
Customer satisfaction		
Improve portfolio management		
Provide on-line portfolio service		
Reduce interaction with customer		
Reduce manual work		
Systems should be customer facing		

Table 17 List of the elements defined in the C.2.4_Motivation View view.

1.17 C.3.1_Strategy View

This chapter describes the "C.3.1_Strategy View" view defined in the "AMC_M7_2.1.4_ArchiMate Viewpoints" view point.

C.3.1_Strategy Viewpoint

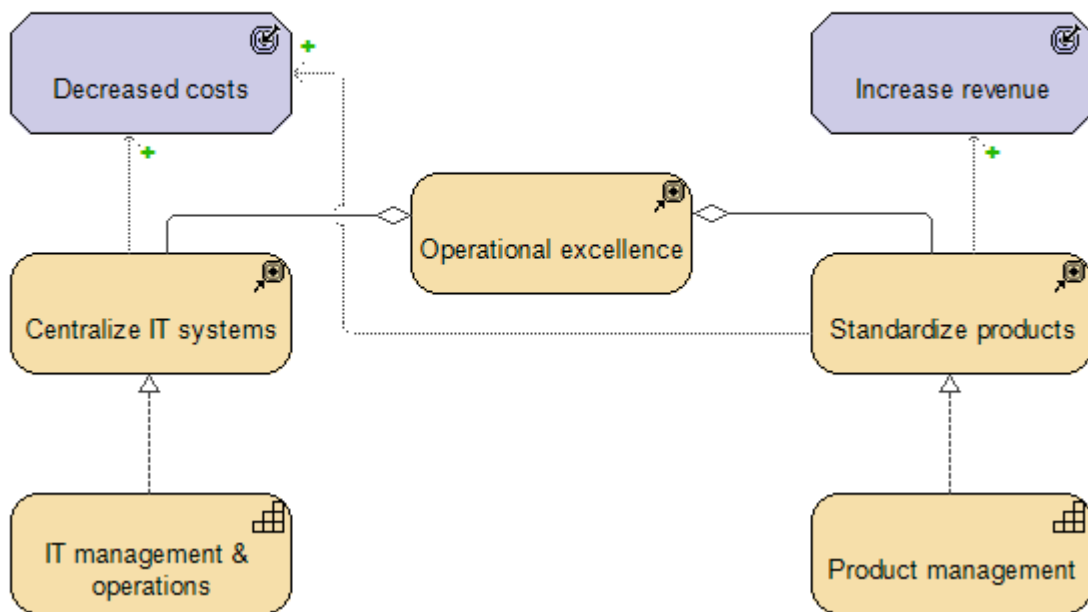

Figure 17 C.3.1_Strategy View

The table below lists the current view's elements.

Name	Description	Refined by
Centralize IT systems		
Decreased costs		
IT management & operations		
Increase revenue		
Operational excellence		

Name	Description	Refined by
Product management		
Standardize products		

Table 18 List of the elements defined in the C.3.1_Strategy View view.

1.18 C.3.2_CapabilityMapView

This chapter describes the "C.3.2_CapabilityMapView" view defined in the "AMC_M7_2.1.4_ArchiMate Viewpoints" view point.

C.3.2_Capability Map Viewpoint

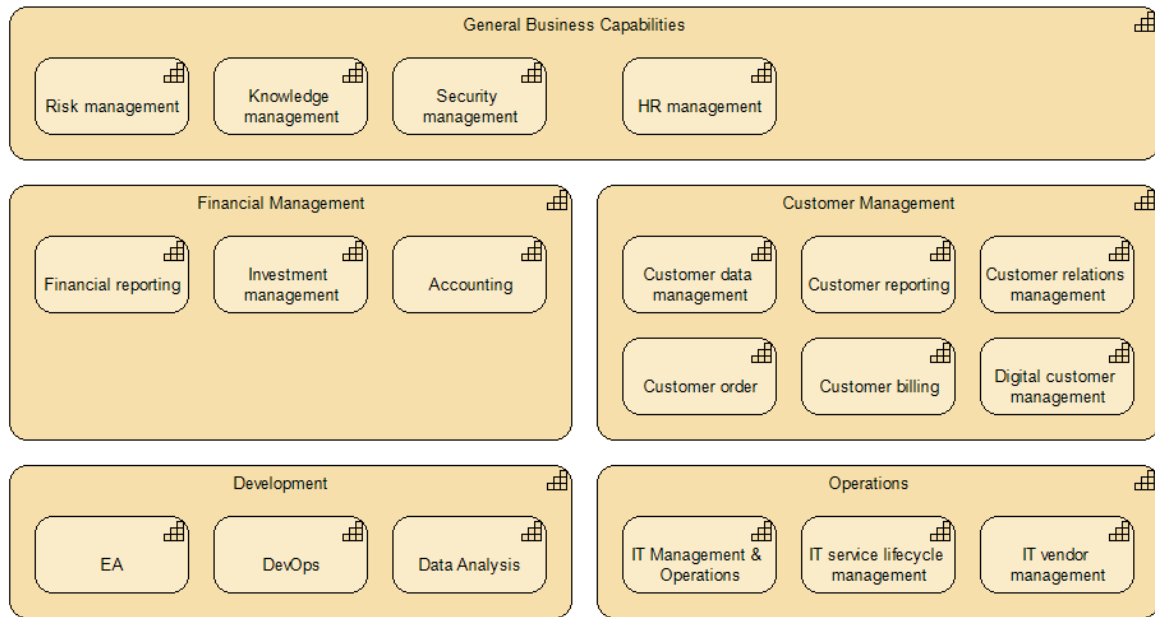

Figure 18 C.3.2_CapabilityMapView

The table below lists the current view's elements.

Name	Description	Refined by
Accounting		
Customer Management		
Customer billing		
Customer data management		
Customer order		
Customer relations management		
Customer reporting		
Data Analysis		
DevOps		
Development		
Digital customer management		
EA		
Financial Management		

Name	Description	Refined by
Financial reporting		
General Business Capabilities		
HR management		
IT Management & Operations		
IT service lifecycle management		
IT vendor management		
Investment management		
Knowledge management		
Operations		
Risk management		
Security management		

Table 19 List of the elements defined in the C.3.2_CapabilityMapView view.

1.19 C.3.3_Outcome Realization View

This chapter describes the "C.3.3_Outcome Realization View" view defined in the "AMC_M7_2.1.4_ArchiMate Viewpoints" view point.

C.3.3_Outcome Realization Viewpoint

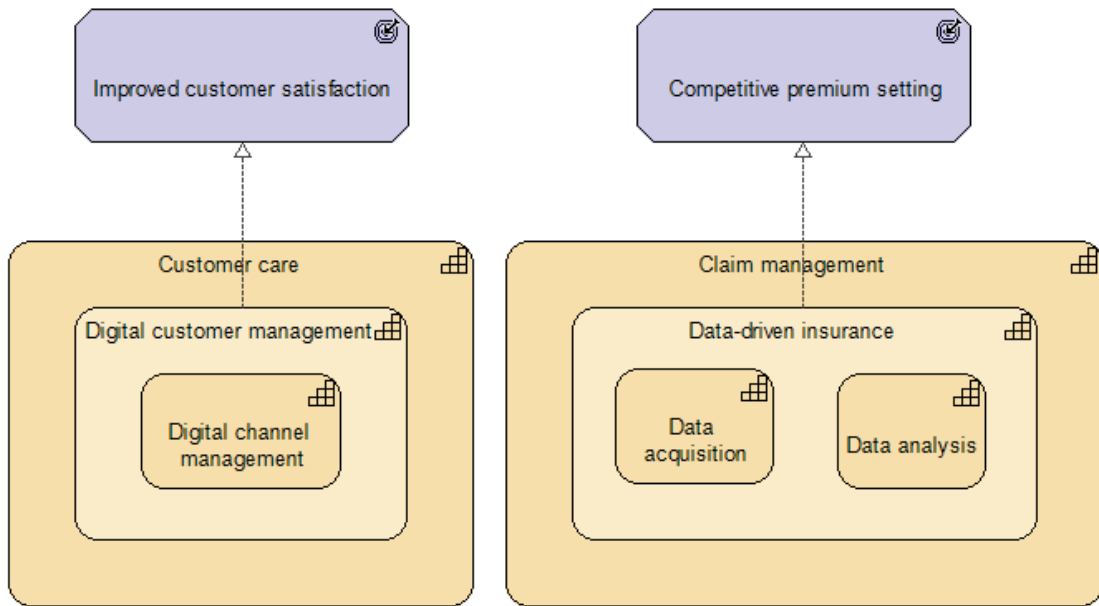

Figure 19 C.3.3_Outcome Realization View

The table below lists the current view's elements.

Name	Description	Refined by
Claim management		
Competitive premium setting		
Customer care		
Data acquisition		

Name	Description	Refined by
Data analysis		
Data-driven insurance		
Digital channel management		
Digital customer management		
Improved customer satisfaction		

Table 20 List of the elements defined in the C.3.3_Outcome Realization View view.

1.20 C.3.4_Resource Map View

This chapter describes the "C.3.4_Resource Map View" view defined in the "AMC_M7_2.1.4_ArchiMate Viewpoints" view point.

C.3.4_Resource Map Viewpoint

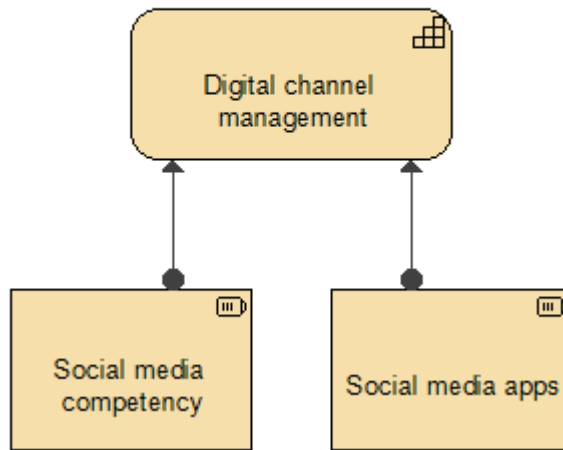

Figure 20 C.3.4_Resource Map View

The table below lists the current view's elements.

Name	Description	Refined by
Digital channel management		
Social media apps		
Social media competency		

Table 21 List of the elements defined in the C.3.4_Resource Map View view.

1.21 C.4.1_Project View

This chapter describes the "C.4.1_Project View" view defined in the "AMC_M7_2.1.4_ArchiMate Viewpoints" view point.

C.4.1_Project Viewpoint

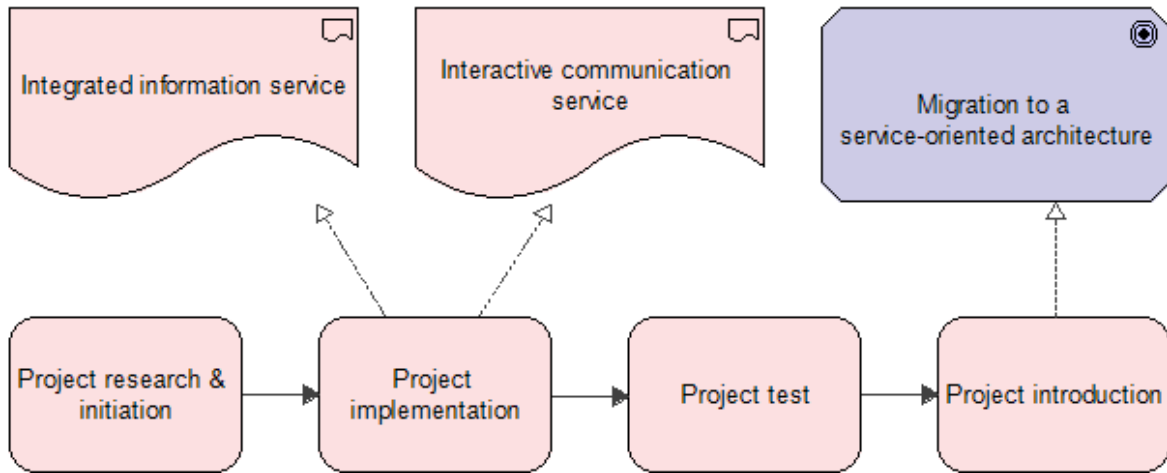

Figure 21 C.4.1_Project View

The table below lists the current view's elements.

Name	Description	Refined by
Integrated information service		
Interactive communication service		
Migration to a service-oriented architecture		
Project implementation		
Project introduction		
Project research & initiation		
Project test		

Table 22 List of the elements defined in the C.4.1_Project View view.

1.22 C.4.2_Migration View

This chapter describes the "C.4.2_Migration View" view defined in the "AMC_M7_2.1.4_ArchiMate Viewpoints" view point.

C.4.2_Migration Viewpoint

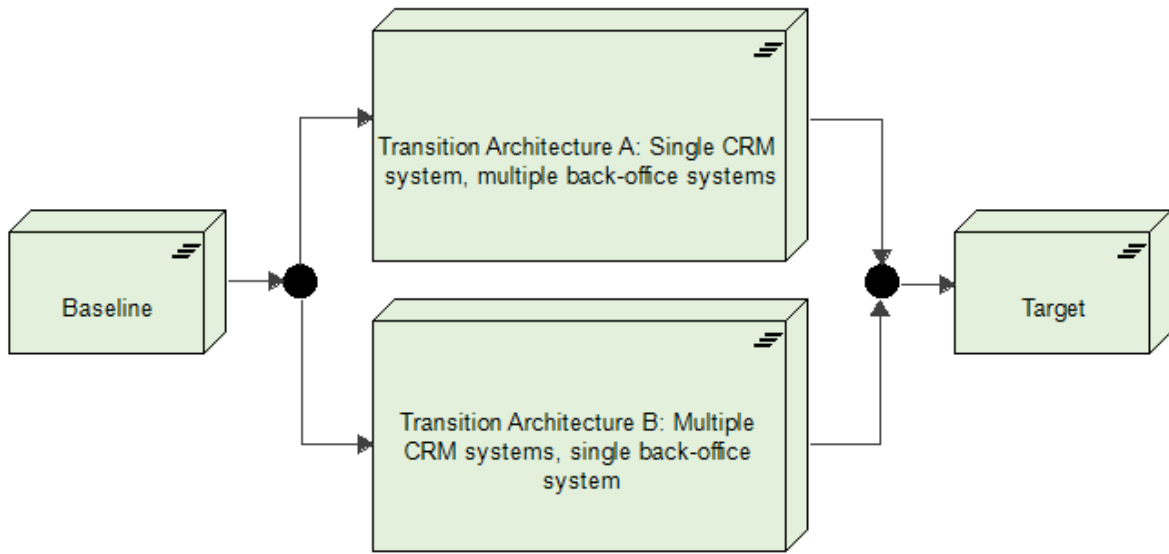

Figure 22 C.4.2_Migration View

The table below lists the current view's elements.

Name	Description	Refined by
Baseline		
Target		
Transition Architecture A: Single CRM system, multiple back-office systems		
Transition Architecture B: Multiple CRM systems, single back-office system		

Table 23 List of the elements defined in the C.4.2_Migration View view.

1.23 C.4.3_Implementation and Migration View

This chapter describes the "C.4.3_Implementation and Migration View" view defined in the "AMC_M7_2.1.4_ArchiMate Viewpoints" view point.

C.4.3_Implementation and Migration Viewpoint

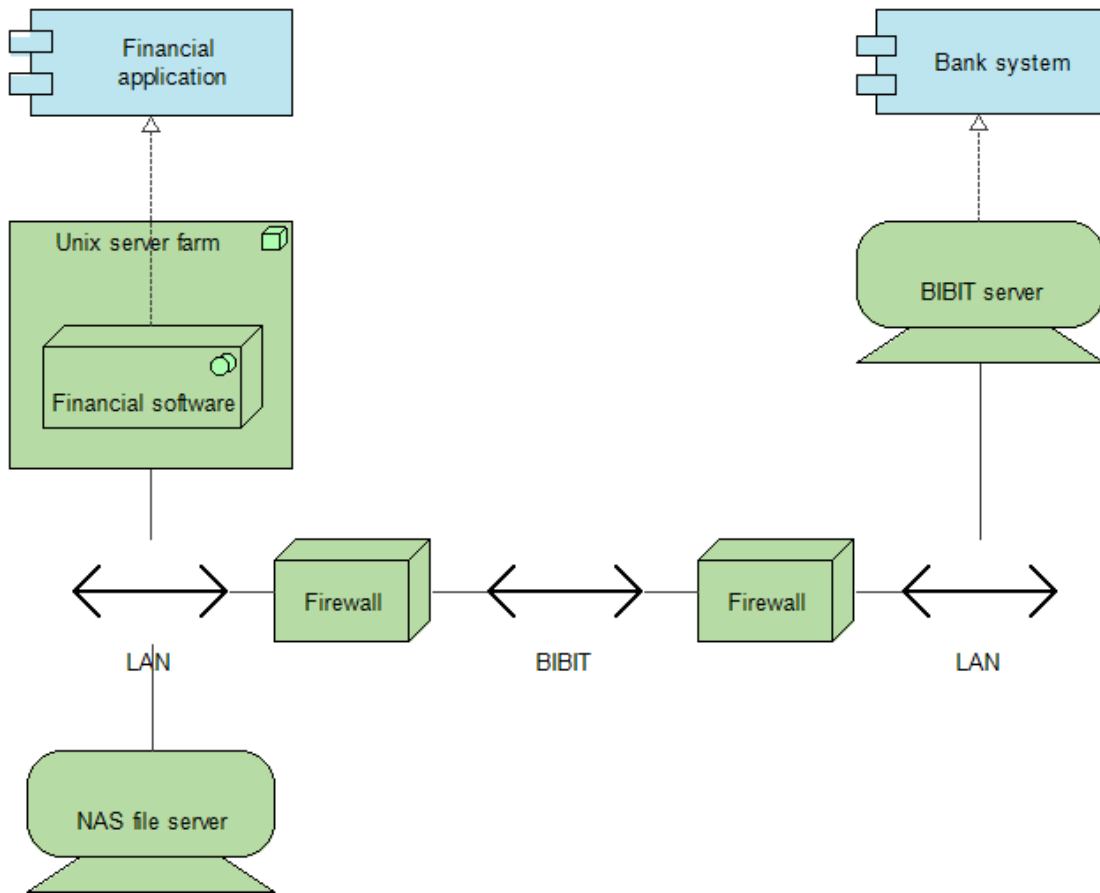

Figure 23 C.4.3_Implementation and Migration View

The table below lists the current view's elements.

Name	Description	Refined by
BIBIT		
BIBIT server		
Bank system		
Financial application		
Financial software		
Firewall		
Firewall		
LAN		
LAN		
NAS file server		
Unix server farm		

Table 24 List of the elements defined in the C.4.3_Implementation and Migration View view.